

Using MATLAB/ Simulink in the designing of Undergraduate Electric Machinery Courses

Mostafa.A. M. Fellani, Daw.E. Abaid*

Control Engineering department Faculty of Electronics Technology, Beni-Walid, Libya
Email: *Dawabaid {at} gmail.com

ABSTRACT: *This paper describes the MATLAB/Simulink realization of the DC motor speed control methods, namely field resistance, armature voltage and armature resistance control methods, and feedback control system for DC motor drives. These simulation models are developed as a part of a software laboratory to support and enhance undergraduate electric machinery courses at the faculty of electronic Technology Beni-walid –Libya.*

Keywords: DC motors; education; software laboratory; MATLAB/Simulink

I. INTRODUCTION

Computer modeling and simulation tools have been extensively used to support and enhance electric machinery courses. MATLAB with its toolboxes such as Simulink [1] and SimPower Systems [2] is one of the most popular software packages used by educators to enhance teaching the transient and steady-state characteristics of electric machines [3-7]. In an effort to restructure and modernize electric machinery courses at the faculty of electronic Technology Beni-walid – Libya, authors have developed Simulink models for induction motor experiments and successfully integrated them into an undergraduate electric machinery course. A software laboratory has been designed to incorporate the simulation models into the laboratory section of the course. In order to have a complete set of simulation tools for electric machinery experiments, the previously designed software laboratory should be extended to include speed control experiments of DC motors. The objective of this paper is to present simulation models of DC motor speed control methods. These models include Simulink models of three most common speed control methods, namely field resistance, armature voltage, and armature resistance control methods, and feedback control system for DC motor drives.

The proposed simulation models are combined with previously developed Simulink models of induction motors.

An Electric Machinery Experiment Toolbox (EMET) has been designed using MATLAB's graphical user interface programming to offer students all simulation models in a single and easy-to-use software package. The simulation models of DC motors are integrated into a control-oriented senior level electric machinery course to enhance the teaching

of the steady-state and dynamic analysis of DC motors. The enhancement is achieved by using the simulation models for various educational activities such as classroom demonstration, exercises, and assignments. It has been observed that with the help of simulation results they obtain, students increase their understanding of DC motor characteristics and dynamic behavior beyond the understanding they gain from classroom lectures and textbooks.

II MATLAB/SIMULINK MODELS OF SPEED CONTROL METHODS

The speed of a DC motor can be varied by controlling the field flux, the armature resistance or the terminal voltage applied to the armature circuit. The three most common speed control methods are field resistance control, armature voltage control, and armature resistance control [10]. In this section, Simulink models of these three methods and feedback control method [10] for DC motor drives for dynamic analysis are presented.

In the field resistance control method, a series resistance is inserted in the shunt-field circuit of the motor in order to change the flux by controlling the field current. It is theoretically expected that an increase in the field resistance will result in an increase in the no-load speed of the motor and in the slope of the torque-speed curve [10]. Figure 1 shows the Simulink implementation of the field resistance control method. A DC motor block of SimPower Systems toolbox is used. The DC motor block implements a separately excited DC motor. An access is provided to the field connections (F+,F-) so that the motor model can be used as a shunt-connected.

The field circuit is represented by an RL circuit (R_f and L_f in series) and is connected between the ports (F+, F-).

The armature circuit consists of an inductor L_a and resistor R_a in series with an electromotive force EA and is connected between the ports (A+,A-).

The load torque is specified by the input port T_L . The electrical and mechanical parameters of the motor could be specified using its dialog box. Observe that 240V DC source is applied to the armature and field circuits. An external resistance R_{f1} is inserted in series with the field circuit to

realize the field resistance speed control. The output port (port m) allows for the Measurement of several variables, such as rotor speed, armature and field currents, and electromechanical Torque developed by the motor. Through the scope and display block, the waveform and steady-state value of the rotor speed can be easily measured in radian per second (rad/s), or the corresponding data can be written to MATLAB's workspace using the data box to make use of other graphical tools available in MATLAB.

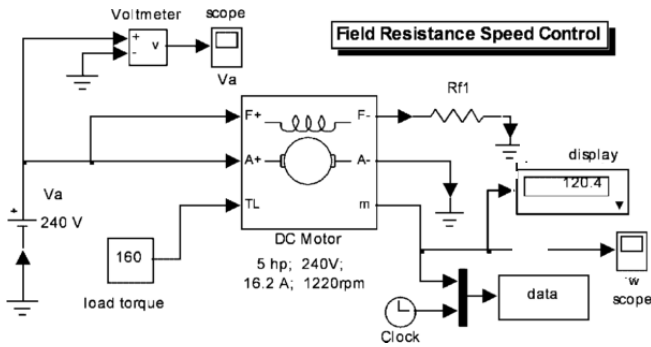

Figure 1 Simulink implementation of field resistance speed control method.

In the armature voltage control method, the voltage applied to the armature circuit, V_a is varied without changing the voltage applied to the field circuit of the motor. Therefore, the motor must be separately excited to use armature voltage control. When the armature voltage is increased, the no-load speed of the motor increases while the slope of the torque-speed curve remains unchanged since the flux is kept constant [10]. Figure 2 shows the Simulink realization of the armature voltage speed control method.

This simulation model is similar to that of the Field resistance control method shown in Figure 1. The main difference is that the armature and field circuit are supplied from two different DC sources to have a separately excited connection. Moreover, the external resistance R_{f1} in Figure 1 is removed in this model.

The armature resistance control is the less commonly used method for speed control in which an external resistance is inserted in series with the armature circuit. An increase in the armature resistance results in a significant increase in the slope of the torque-speed characteristic of the motor while the no-load speed remains constant [10]. Simulink model of this method is not shown here since it is almost the same as that of the field resistance control method shown in Figure 1. The only difference is that R_{f1} resistance in Figure 1 is removed and an external resistance R_{a1} is inserted in series with the armature circuit between the ports (A+,A-) to vary the

armature resistance.

The block diagram of feedback speed control system for DC motor drives is shown in Figure 3a. The control objective is to make the motor speed follow the reference input speed change by designing an appropriate controller. The proportional-integral (PI controller) is used to reduce or eliminate the steady state error between the measured motor speed (ω) and the reference speed (ω_{ref}) to be tracked. The transfer function of PI controller is given by [10]

$$G_c(s) = K_p + K_I/s \quad (1)$$

Where K_p and K_I are the proportional and integral gains. In the feedback control system, the dynamics of the DC motor can be described either by a transfer function or by the following state-space equations:

$$\begin{aligned} \dot{x}_1 &= -\frac{R_a}{L_a}x_1 - \frac{K}{L_a}x_2 + \frac{1}{L_a}u \\ \dot{x}_2 &= \frac{K}{J}x_1 - \frac{B}{J}x_2 - \frac{1}{J}T_L \end{aligned} \quad (2)$$

where $x_1=i_a$, $x_2=n_m$ are the armature current and motor speed in rad/s, respectively; u is the voltage input applied to armature circuit, T_L is the load torque, J is the combined moment of inertia of the load and the rotor; B is the equivalent viscous friction constant of the load and the motor, and K is the design constant depending on the construction of the motor. Figure 3b shows the Simulink model of feedback control system. The Simulink representation of the DC motor drive system can give students a clear vision of the block diagram representation of an electric machine control system, the transfer functions of the controller, and dynamic models of DC motors. Students can easily evaluate the performance of a chosen controller to check if the desired control goal for the motor speed is achieved.

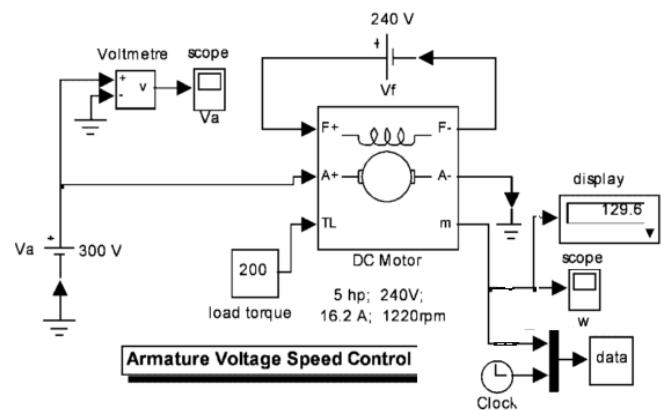

Figure 2 Simulink implementation of armature voltage speed control method.

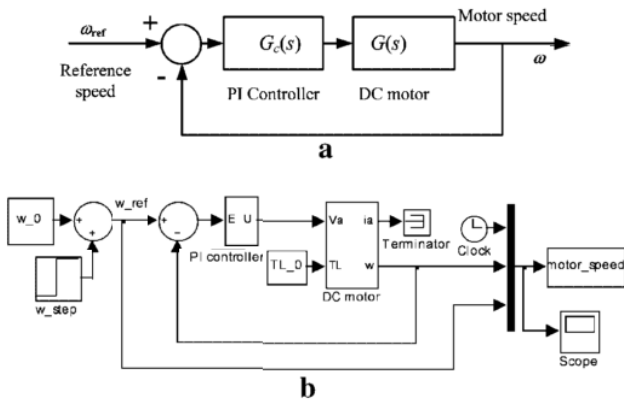

Figure 3 Feedback control system for DC motor speed control: (a) block diagram; (b) Simulink model.

III SIMULATION RESULTS

This section presents simulation results for the speed control methods and DC motor feedback control system. The torque-speed curves for the speed control methods are determined using the Simulink models presented in the previous section. For this purpose, a 5- Horse Power (HP) DC motor of 240 V rating 1,220 r/min is used in the simulation models. The equivalent circuit parameters of the motor are:

$$R_f = 240 \Omega, L_f = 120H, R_a = 0.6\Omega.$$

For the field resistance control, first, the nominal Value of the field resistance $R_f = 240 \Omega$ is selected and simulations are run for several values of load torque in the range of $T_L = 0- 500$ N.m to determine the steady-state value of the speed at each load level. In order to investigate the effect of an increase in the field resistance on the torque-speed characteristic, $R_{f1} = 60\Omega$ external resistance is then inserted in series with the field circuit as illustrated in Figure 1 and simulations are repeated for the same load levels. The torque-speed curves for both resistance values are shown in Figure 4. This figure clearly shows an increase in the slope of the curve as well as in the no-load speed of the motor with respect to an increase in the field resistance. It must also be noted that over the range from no-load to full-load conditions ($T_L = 0-300$ N.m), an increase in R_f causes an increase in the motor speed. On the other hand, at very slow speed ($T_L > 300$ N.m), an increase in R_f will decrease the speed of the motor [10]. For the armature voltage control, simulations are performed using the model shown in Figure 2 for three different armature voltages, $V_a = 180, 240$ and $300V$ while the voltage applied to the field circuit is kept constant at its nominal value $240 V$. Figure 5 compares the torque-speed characteristics. Figure 5 clearly illustrates that the torque-speed curve is shifted upward by increasing the armature voltage while the slope of the curve remains unchanged, as it is theoretically expected. Finally, simulations are performed for three different values of the armature resistance $R_a = 0.6, 1.2$ and 1.8Ω in order to investigate the effect of armature resistance on the shape of the torque-speed curve. Simulation results are shown in Figure 6. Observe that when the armature

resistance is increased the slope of the motor's torque-speed characteristic, increases drastically, making it operate more slowly if loaded. Figure 7 illustrates the response of the motor speed to a step increase in the reference speed for different values of the proportional gain (K_p) while the integral gain is kept constant at $K_i = 1$.

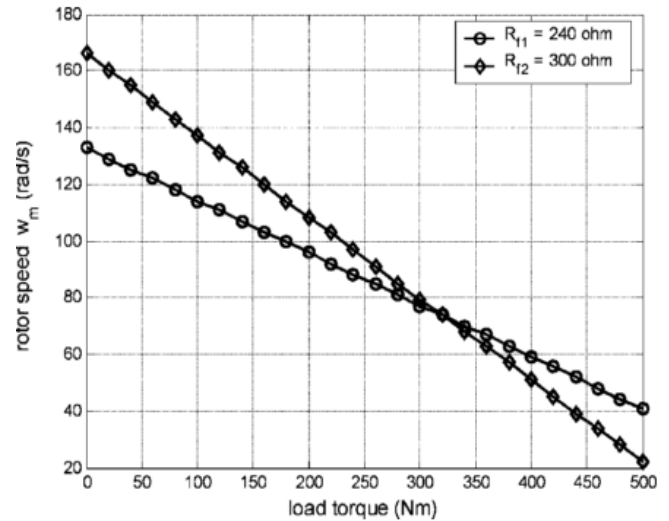

Figure 4 Torque-speed characteristics for two different field resistances.

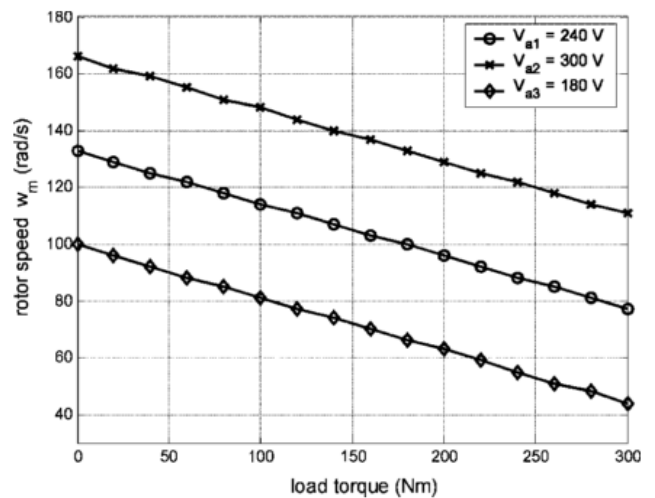

Figure 5 Torque-speed characteristics for three different armature voltages.

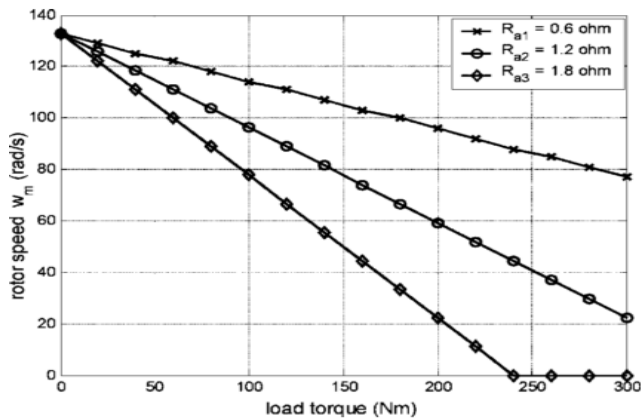

Figure 6 Torque-speed characteristics for three different resistances.

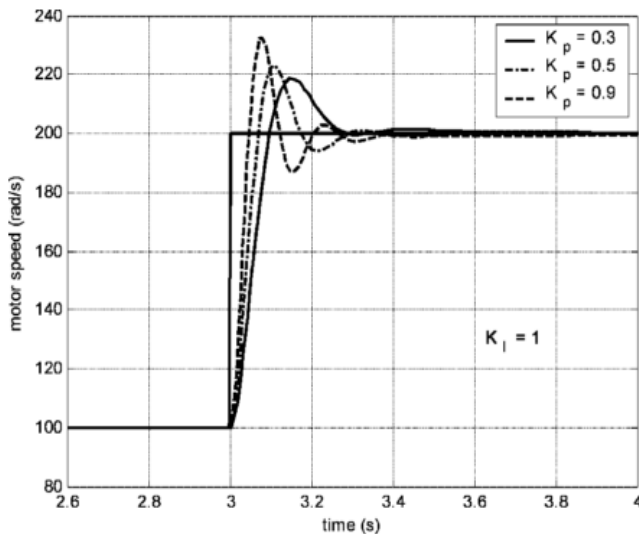

Figure 7 Motor speed for different PI gain values.

Parameters of The state-space equation model of the DC motor given in Equation (2) can be found in Reference [10]. With the help of simulation results, students can more effectively examine the controller performance and investigate quantitative effects of the PI controller gains (K_p and K_i) on the transient and steady-state behavior of the motor speed. Moreover, simulation results give students better opportunities to verify the theories learned from the lecture. For example, they can clearly see that the integral control eliminates the steady-state error while increase in the proportional gain adversely affects the transient behavior of the motor speed such as increasing the maximum overshoot and settling time.

IV THE EDUCATIONAL USE OF THE MODELS

This section describes how the proposed Simulink models were used in a senior level machinery course (Electric Machinery II) in the Department of Control Engineering, at the faculty of electronic technology beni-walid Libya.

This course is a control-oriented course that offers both

steady-state and dynamic operation principles and mathematical models of DC machines. For the steady-state analysis, the topics covered by the course are the structure of DC machines, per-phase equivalent circuit model, torque-speed characteristic, and speed control methods by varying the field flux, the armature resistance and the armature applied voltage [10]. In the dynamic analysis, the course covers the fundamentals of linear control theory, dynamic models of DC machines such as transfer function or state-space equation models, feedback control design, and its application into DC motor drives for speed control.

After the steady-state equivalent circuit model, Operation principles, torque-speed characteristics, and speed control methods are covered in the class, the instructor uses Simulink models of the field resistance control(Fig.1), armature voltage control(Fig.2), and armature resistance control to demonstrate the effects of equivalent circuit parameters on the motor speed under a wide range of loading conditions. After the demonstration, students are asked to obtain the torque- speed characteristics for each control method and compare them with the theoretical results learned from the lecture. Students through this exercise should have a basic understanding of the steady-operation of DC motors and various speed control techniques.

Moreover, after having enough experiences with the simulation models, the following exercises are assigned to students:

- * Obtain the plot of motor speed in rpm versus the field resistance (R_f) at a given load level, say $T_L=100$ N.m and using MATLAB curve fitting tool, find an equation that describes motor speed as a function of R_f .
- *Obtain the plot of motor speed in rpm versus the Armature resistance (R_a) at a given load level, say $T_L=100$ and using MATLAB curve fitting tool, find an equation that describes motor speed as a function of R_a .
- *Obtain the plot of motor speed in rpm versus the armature voltage (V_a) at a given load level, say $T_L=100$ N.m and using MATLAB curve fitting tool, find an equation that describes motor speed as a function of V_a .

An example of simulations obtained by students for given assignments is presented in Figure 8 that shows motor speed (rpm) as a function of the field resistance R_f . Note that a linear curve that fits the simulation data is found and simulation data are compared with those obtained from the linear equation. Note that errors (residual) shown in the lower part of Figure 8 are negligible indicating that motor speed can be described as a linear function of R_f (i.e., $n_m=3.46 \cdot R_f+246$).

The simulation result clearly shows students that an increase

in field resistance increases the motor speed. Moreover, with the help of these simulation results and curve fitting students will be able to determine motor speed easily for a wide range of equivalent circuit parameters. For the dynamic analysis, Simulink model of feedback control system for DC motor drives (Fig.3b) is used to illustrate the feedback control concept as applied to DC motor drives and to demonstrate them. The design of a controller to achieve the desired control goal on torque and speed of the DC motor. Similarly, students are asked to run simulations for various values of PI control gains to evaluate the performance of different controllers and to investigate the speed dynamics of closed-loop DC motor control system. A typical result obtained by students is shown in Figure 9. This figure depicts the response of the motor speed to a step increase in the reference speed for different values of the integral gain K_I while the proportional gain is kept constant at $K_p=0.1$.

Such simulation exercises help students develop concepts and skills in feedback control design and their applications into DC motor drive system.

The use of the proposed simulation models was assessed both formally with student evaluations and informally from discussions with students. Since the models were introduced to all students within a course. The student response to the use of the models has been very positive. The majority of students indicate that having a tool that is easy to use allows them to comprehend torque-speed characteristics and speed control methods. Students increase their understanding of steady state and dynamic behavior of DC motors beyond the understanding they gain from classroom lectures and textbooks. They especially appreciate the integrative teaching approach that combines traditional steady state Analysis of DC motors with dynamic approaches (feedback control) that are supported by simulation models. Students suggest that MATLAB and Simulink/ SimPower Systems should be integrated into other power system and control courses as well. Moreover, with the extensive use of simulation models, students have become familiar with the widely used numerical simulation environment of MATLAB, which they will be able to use subsequently for their senior design projects or research.

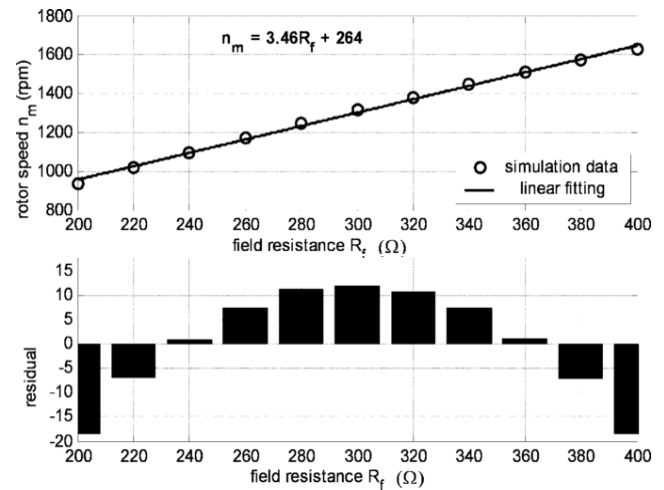

Figure 8 Motor speed versus field resistance: Linear curve fitting and errors

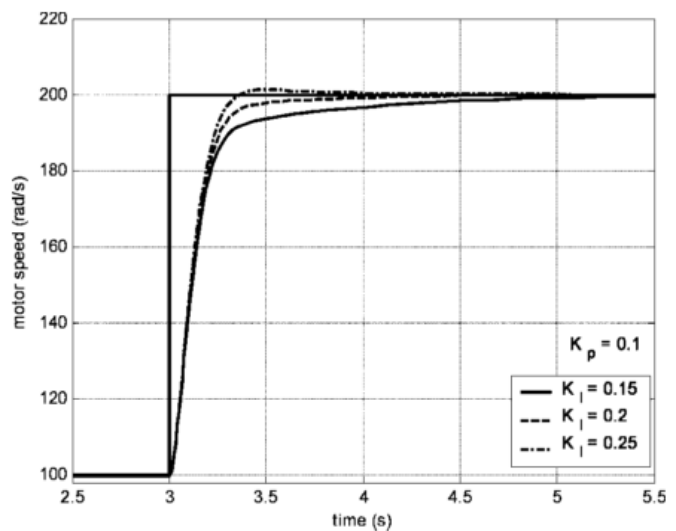

Figure 9 Motor speed for different PI gain values.

V CONCLUSIONS

Simulation models of DC motor speed control methods and feedback control system for DC motor drives have been developed using MATLAB/Simulink. It has been shown that proposed simulation models correctly predict the effect of field resistance, armature voltage, and resistance on the torque-speed characteristic of the DC motor. Furthermore, Simulink models have been successfully integrated into an electric machinery course as a part of the software laboratory.

The teaching of both the steady-state and dynamic analysis of DC motors has been enhanced using the simulation models. Simulated examples help students increase their understanding of DC motor operation, fundamentals of dynamic system controls and its application into DC motor speed control, providing them a complete view of a controllable DC machine and drive systems. Future work will involve further development of simulation models to include power electronic

converter as a DC voltage source.

REFERENCES

- [1] SIMULINK, Model-based and system-based design, using Simulink, MathWorks Inc., Natick, MA, 2000.
- [2] SimPowerSystems for use with Simulink, user's guide, MathWorks Inc., Natick, MA, 2002.
- [3] M. H. Nehrir, F. Fatehi, and V. Gerez, Computer modeling for enhancing instruction of electric machinery, IEEE Trans Educ 38 (1995), 166-170.
- [4] W. M. Daniels and A. R. Shaffer, Re-inventing the electrical machines curriculum, IEEE Trans Educ 41 (1998), 92-100.
- [5] C.-M. Ong, Dynamic simulation of electric machinery using MATLAB/SIMULINK, Prentice Hall, Upper Saddle River, NJ, 1998.
- [6] K. L. Shi, T. F. Chan, Y. K. Wong, and S. L. Ho, Modeling and simulation of the three-phase induction motor using Simulink, Int J Electr Eng Educ 36 (1999), 163-172.
- [7] S. Li and R. Chaloo, Restructuring an electric machinery course with an integrative approach and computer-assisted teaching methodology, IEEE Trans Educ 49 (2006), 16-28.
- [8] S. Ayasun and C. O. Nwankpa, Induction motor test using Matlab/Simulink and their integration into undergraduate electric machinery courses, IEEE Trans Educ 48 (2005), 37-46.
- [9] S. Ayasun and C. O. Nwankpa, Transformer tests Using MATLAB/Simulink their integration into undergraduate electric machinery courses, Comput Appl Eng Educ 14 (2006), 142-150.
- [10] S. J. Chapman, Electric machinery fundamentals, 3rd ed., WCB/McGraw-Hill, New York, 1998.